

Features

- 2-channel isolated barrier
- 24 V DC supply (Power Rail)
- Input 2-wire and 3-wire SMART transmitters and 2-wire SMART current sources
- Output 0/4 mA ... 20 mA current sink/current source
- Terminals with test points
- Up to SIL 2 acc. to IEC 61508

Function

This isolated barrier is used for intrinsic safety applications. The device supplies 2-wire and 3-wire SMART transmitters, and can also be used with 2-wire SMART current sources. It transfers the analog input signal to the safe area as an isolated current value. Digital signals may be superimposed on the input signal in the hazardous or non-hazardous area and are transferred bi-directionally. The device provides a sink mode or a source mode output on the safe area terminals. The device has an internal resistor. Use this resistor if the HART communication resistance in the control circuit is too low. Test sockets for the connection of HART communicators are integrated into the terminals of the device.

Application

- The device supports the following SMART protocols:
- HART
 - BRAIN
 - Foxboro

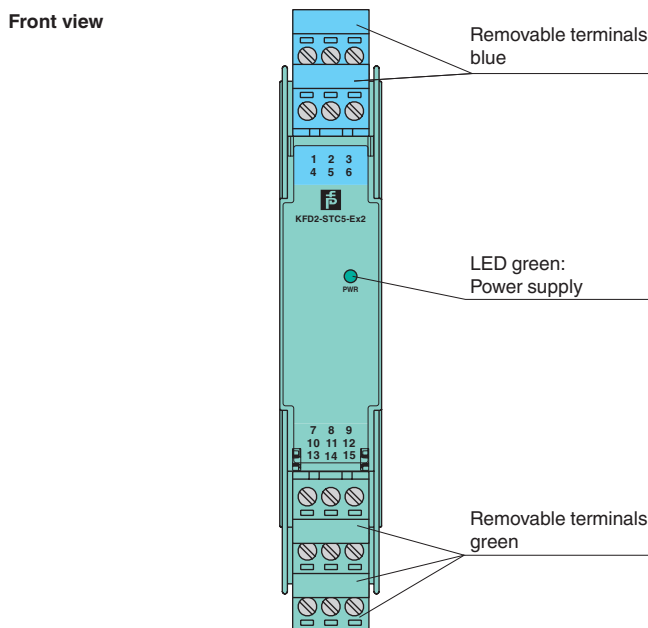

Assembly

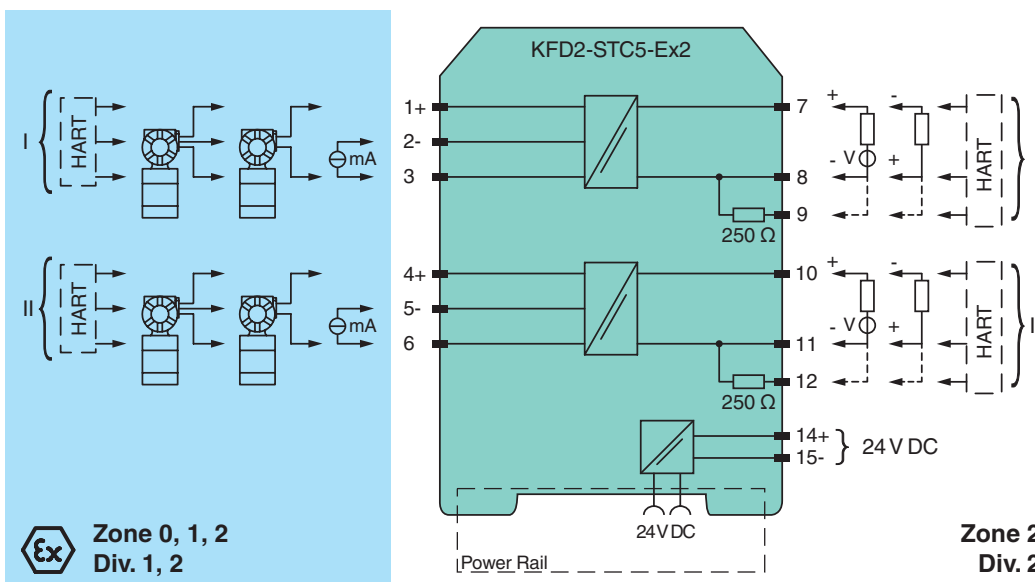

Connection



Release date 2019-04-04 17:37 Date of issue 2019-04-04 203645_eng.xml

General specifications		
Signal type		Analog input
Functional safety related parameters		
Safety Integrity Level (SIL)		SIL 2
Supply		
Connection		Power Rail or terminals 14+, 15-
Rated voltage	U_r	18 ... 30 V DC
Ripple		within the supply tolerance
Power dissipation		≤ 1.4 W at maximum load
Power consumption		≤ 2.6 W at maximum load
Input		
Connection side		field side
Connection		terminals 1+, 2-, 3; 4+, 5-, 6
Input signal		0/4 ... 20 mA
Input resistance		≤ 265 Ω terminals 2-, 3; 5-, 6 , ≤ 330 Ω terminals 1+, 3; 4+, 6
Available voltage		≥ 16 V at 20 mA , terminals 1+, 3; 4+, 6
Output		
Connection side		control side
Connection		terminals 7+, 8-, 9-; 10+, 11-, 12- (sink) terminals 7-, 8+, 9+; 10-, 11+, 12+ (source) see additional information
Load		0 ... 600 Ω
Output signal		0/4 ... 20 mA (overload > 25 mA)
Ripple		≤ 50 μA _{rms}
External supply (loop)		2 ... 30 V DC
Transfer characteristics		
Deviation		at 20 °C (68 °F), 0/4 ... 20 mA ≤ 10 μA incl. calibration, linearity, hysteresis, loads and fluctuations of supply voltage
Influence of ambient temperature		≤ 0.25 μA/K
Frequency range		field side into the control side: band width with 1 V _{pp} signal 0 ... 7.5 kHz (-3 dB) safe area to hazardous area: band width with 1 V _{SS} signal 0.3 ... 7.5 kHz (-3 dB)
Settling time		200 μs
Rise time/fall time		100 μs
Galvanic isolation		
Output/power supply		functional insulation, rated insulation voltage 50 V AC
Output/Output		functional insulation, rated insulation voltage 50 V AC
Indicators/settings		
Display elements		LED
Labeling		space for labeling at the front
Directive conformity		
Electromagnetic compatibility		
Directive 2014/30/EU		EN 61326-1:2013 (industrial locations)
Conformity		
Electromagnetic compatibility		NE 21:2012 EN 61326-3-2:2008
Degree of protection		IEC 60529:2001
Protection against electrical shock		UL 61010-1:2012
Ambient conditions		
Ambient temperature		-20 ... 60 °C (-4 ... 140 °F)
Mechanical specifications		
Degree of protection		IP20
Connection		screw terminals
Mass		approx. 200 g
Dimensions		20 x 124 x 115 mm (0.8 x 4.9 x 4.5 inch) , housing type B2
Mounting		on 35 mm DIN mounting rail acc. to EN 60715:2001
Data for application in connection with hazardous areas		
EU-Type Examination Certificate		CML 17 ATEX 2031X
Marking		 II (1)G [Ex ia Ga] IIC  II (1)D [Ex ia Da] IIIC  I (M1) [Ex ia Ma] I
Input		[Ex ia Ga] IIC, [Ex ia Da] IIIC, [Ex ia Ma] I
Supply		
Maximum safe voltage	U_m	250 V (Attention! The rated voltage can be lower.)
Equipment		terminals 1+, 3-, 4+, 6-
Voltage	U_o	26.2 V

Release date 2019-04-04 17:37 Date of issue 2019-04-04 203645_eng.xml

Voltage	U_q	27.25 V
Current	I_o	93 mA
Power	P_o	634 mW
Permissible connection values [EEx ia]		
Equipment terminals 2-, 3+; 5-, 6+		
Voltage	U_i	30 V
Current	I_i	115 mA
Power	P_i	max 1 W
Voltage	U_o	2 V
Current	I_o	8.5 mA
Power	P_o	4.3 mW
Permissible connection values [EEx ia]		
Equipment terminals 1+, 2/3-; 4+, 5/6-		
Voltage	U_o	26.2 V
Voltage	U_q	27.25 V
Current	I_o	115 mA
Power	P_o	784 mW
Certificate	CML 17 ATEX 3030X	
Marking	⊕ II 3G Ex ec IIC T4 Gc	
Galvanic isolation		
Input/Output	safe electrical isolation acc. to IEC/EN 60079-11:2012, voltage peak value 375 V	
Input/power supply	safe electrical isolation acc. to IEC/EN 60079-11:2012, voltage peak value 375 V	
Directive conformity		
Directive 2014/34/EU	EN 60079-0:2012+A11:2013 , EN 60079-11:2012 , EN 60079-7:2015	
International approvals		
UL approval		
Control drawing	116-0439 (cULus)	
IECEX approval	IECEX CML 17.0016X	
Approved for	[Ex ia Ga] IIC , [Ex ia Da] IIIC , [Ex ia Ma] I , Ex ec IIC T4 Gc	
General information		
Supplementary information	Observe the certificates, declarations of conformity, instruction manuals, and manuals where applicable. For information see	
Accessories		
Optional accessories	<ul style="list-style-type: none"> - power feed module KFD2-EB2(.R4A.B)(.SP) - universal power rail UPR-03(-M)(-S) - profile rail K-DUCT-BU(-UPR-03) 	

Additional Information

The device provides 2 outputs on the control side terminals. These outputs can be operated in any combination of the current sink operating mode and current source operating mode. Please refer to the following diagram for connection.

